

BirdsMouth

Orientation = start

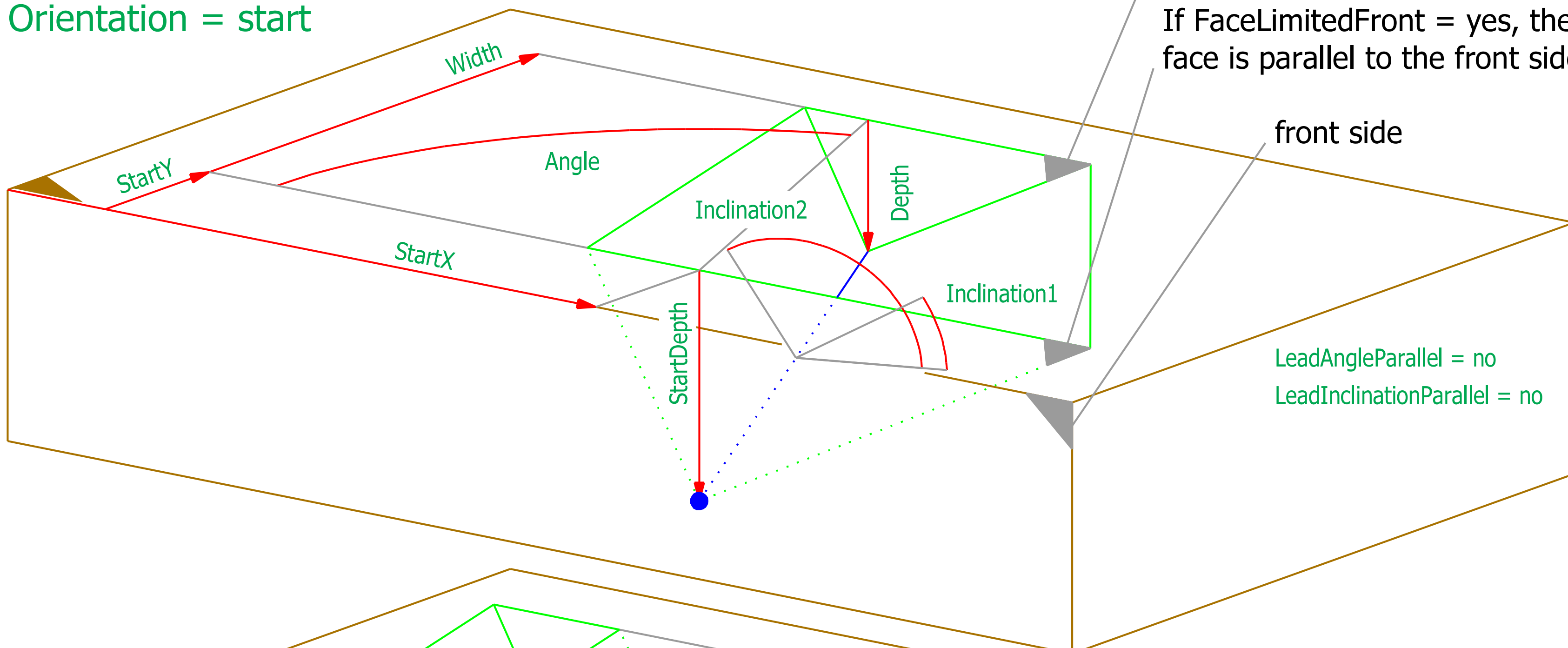

If FaceLimitedBack = yes, then this face is parallel to the front side.

If FaceLimitedFront = yes, then this face is parallel to the front side.

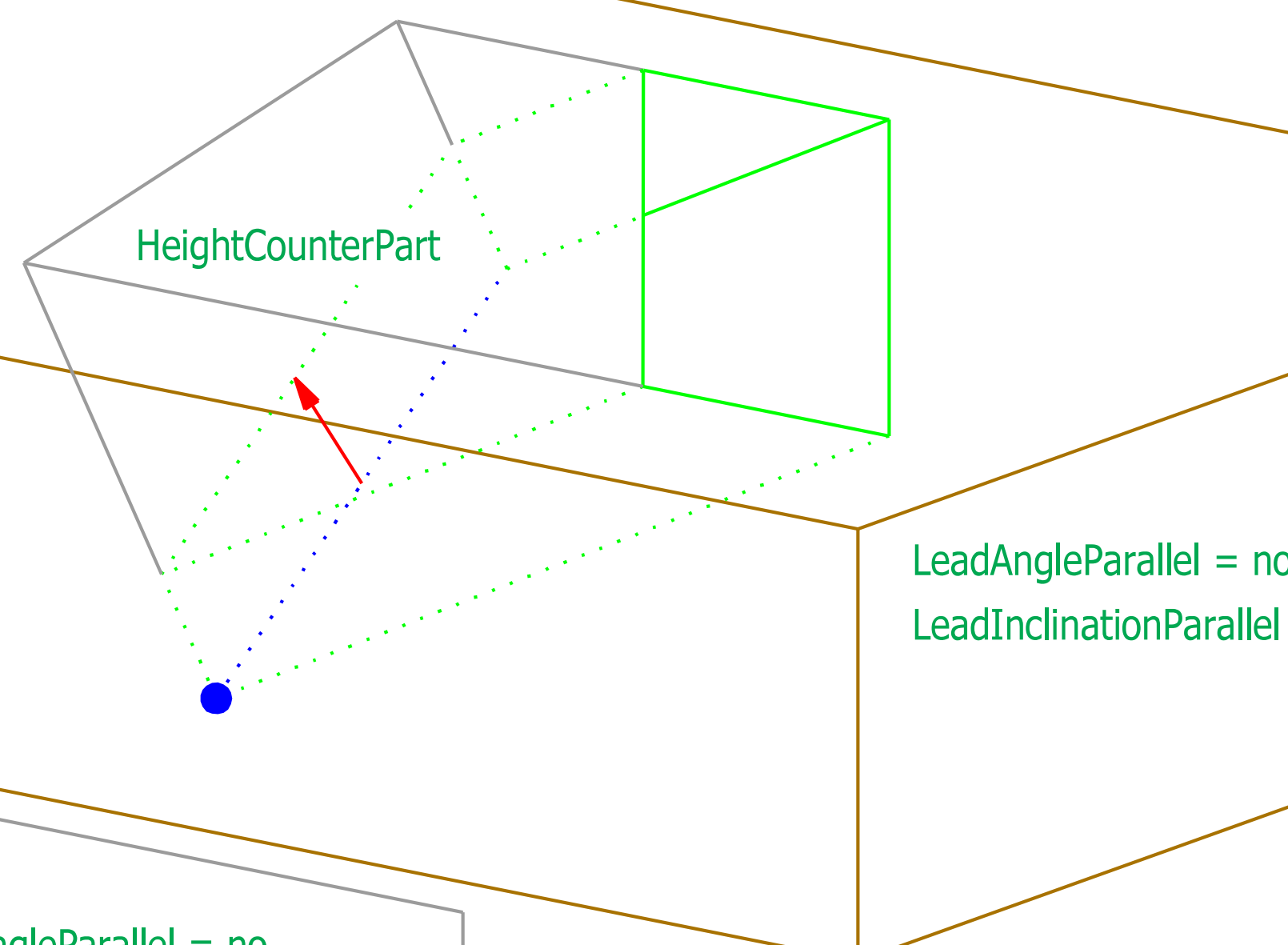
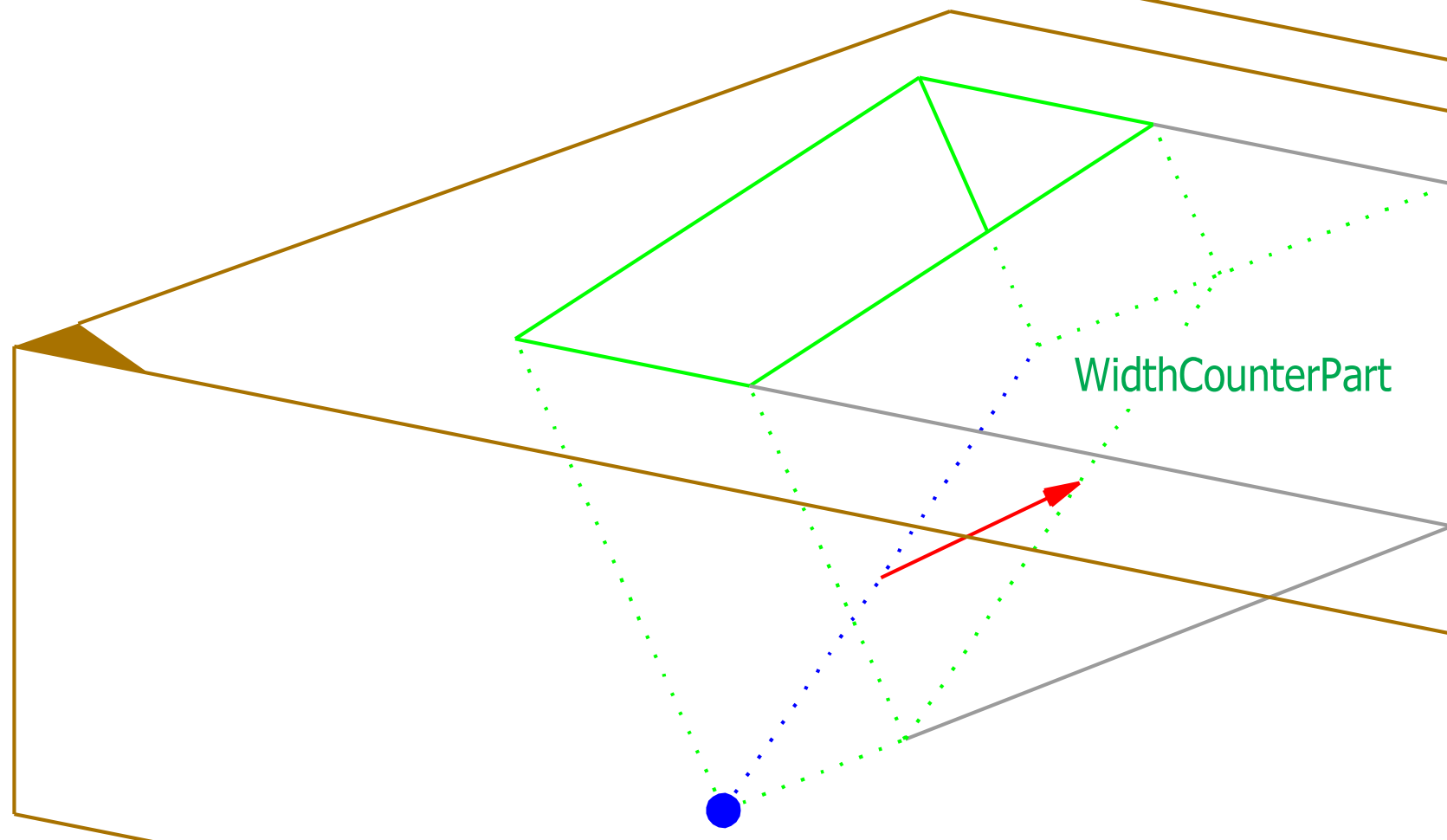

LeadAngleParallel = no
LeadInclinationParallel = no

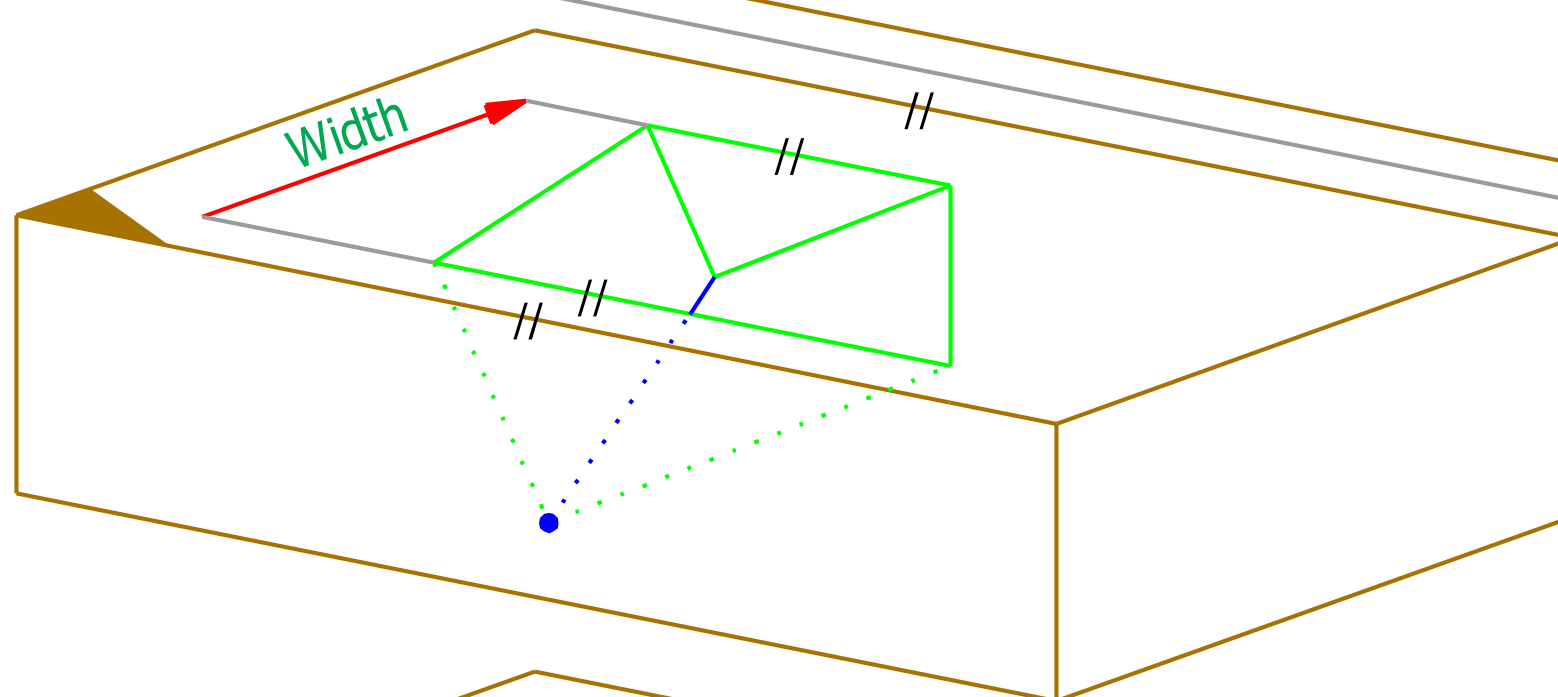

LeadAngleParallel = no
LeadInclinationParallel = no

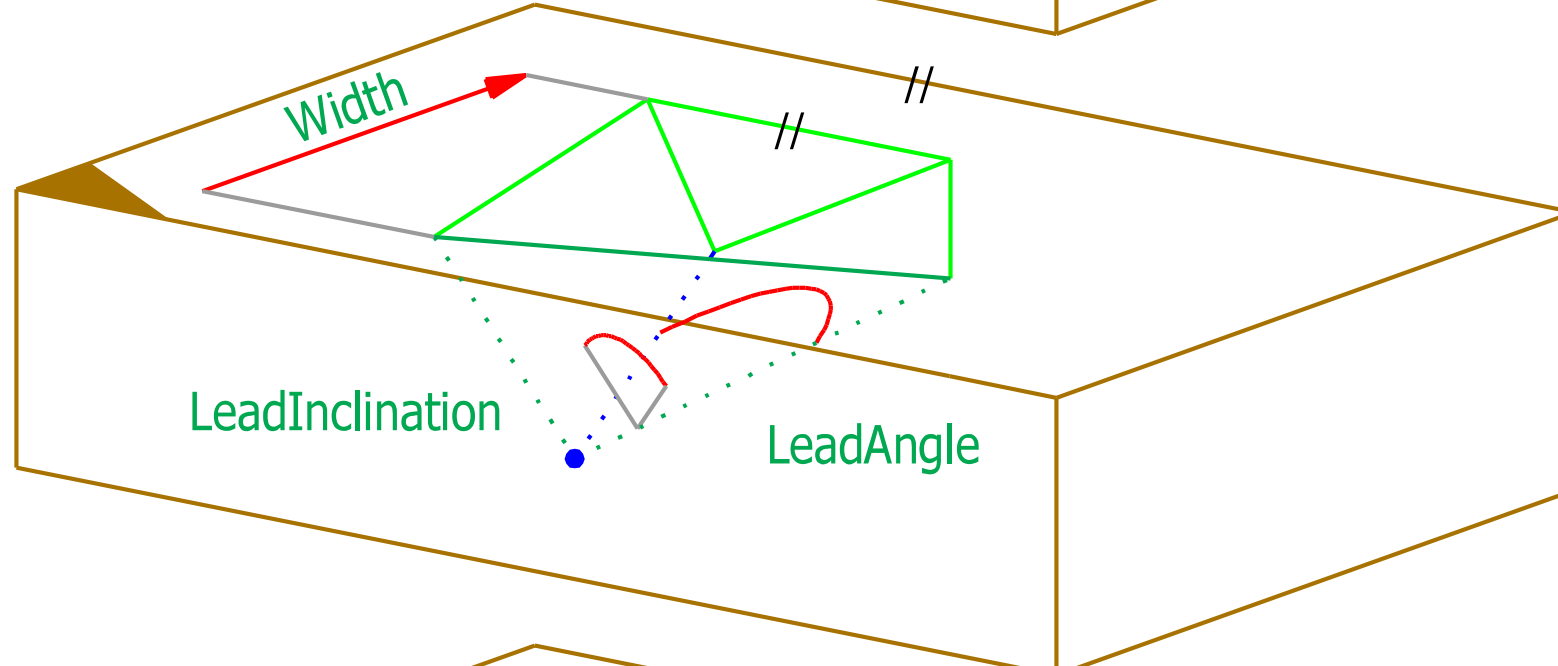

Location of LeadAngle

FaceLimitedFront = yes
LeadAngleParallel = yes
LeadInclinationParallel = yes

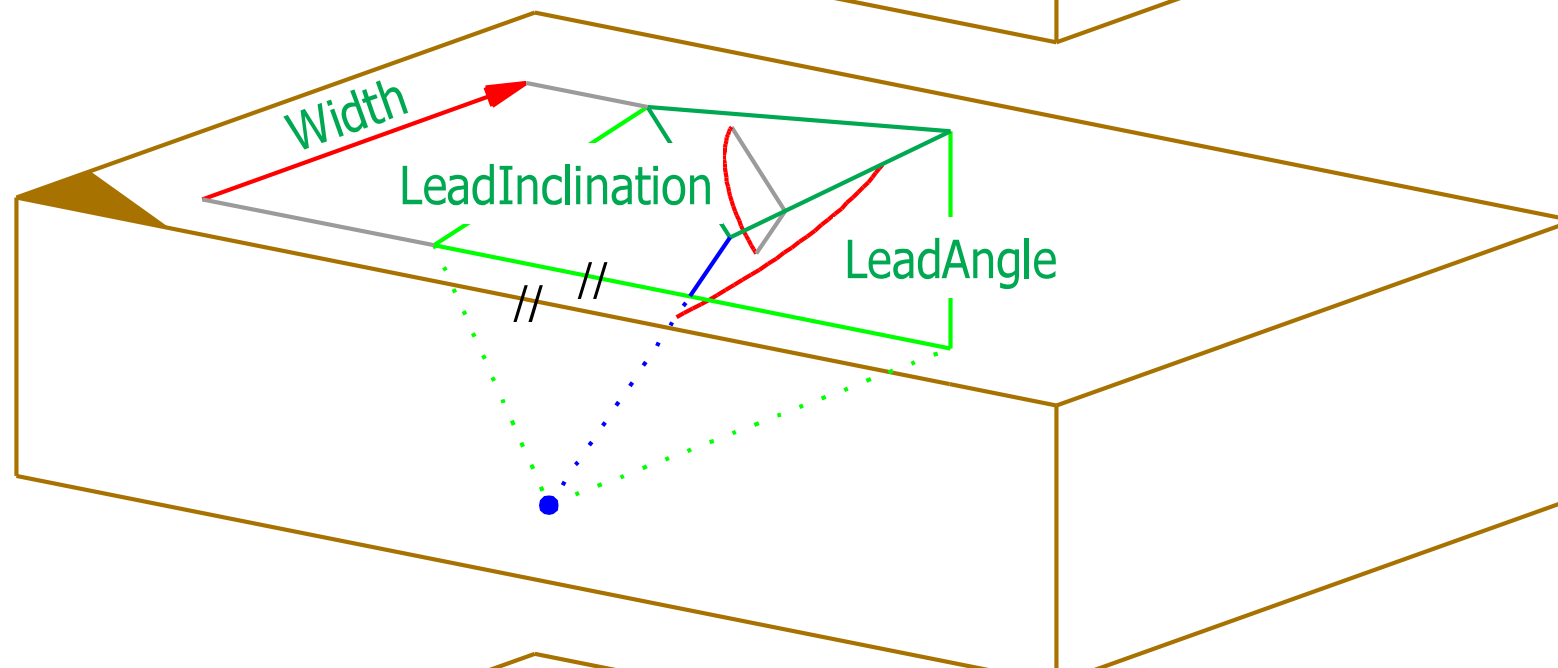

FaceLimitedBack = yes
LeadAngleParallel = yes
LeadInclinationParallel = yes

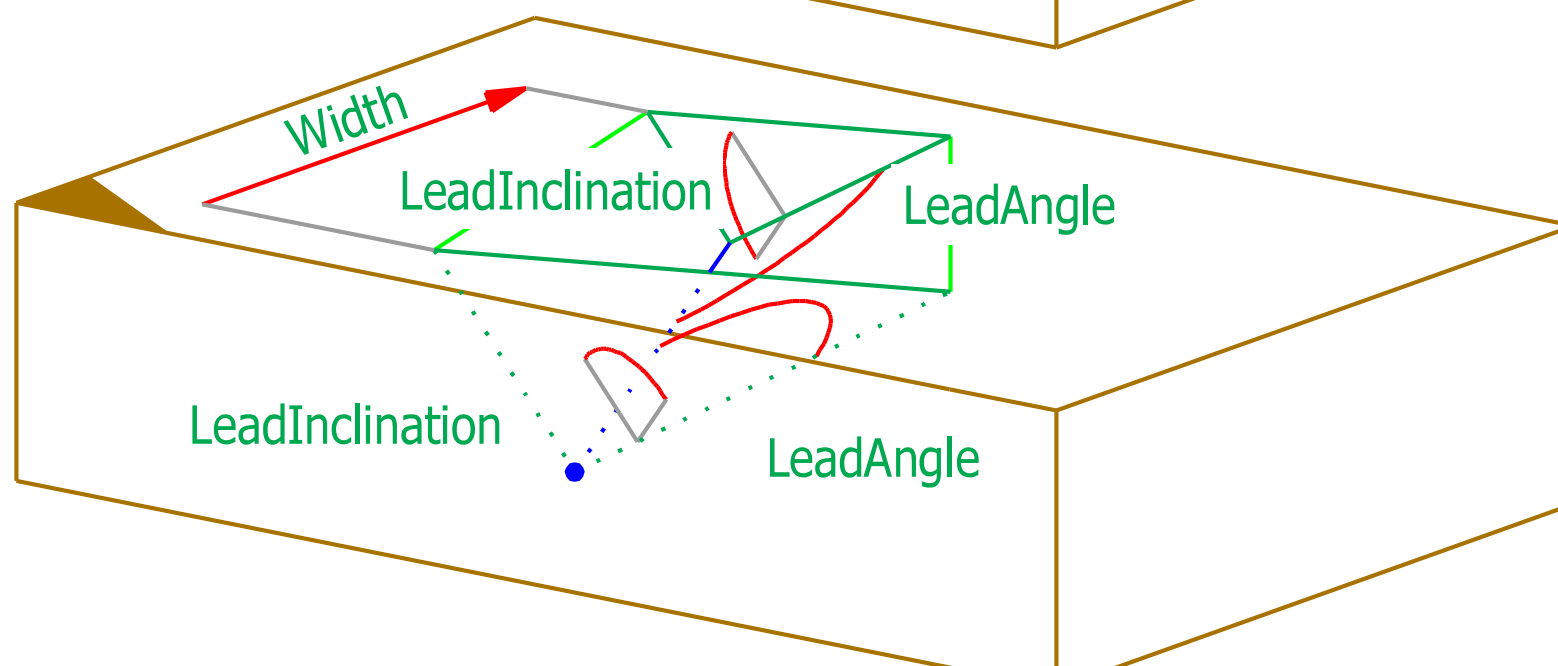

FaceLimitedFront = yes
FaceLimitedBack = yes
LeadAngleParallel = yes
LeadInclinationParallel = yes

Simple example

Angle = 90
StartDepth = Depth

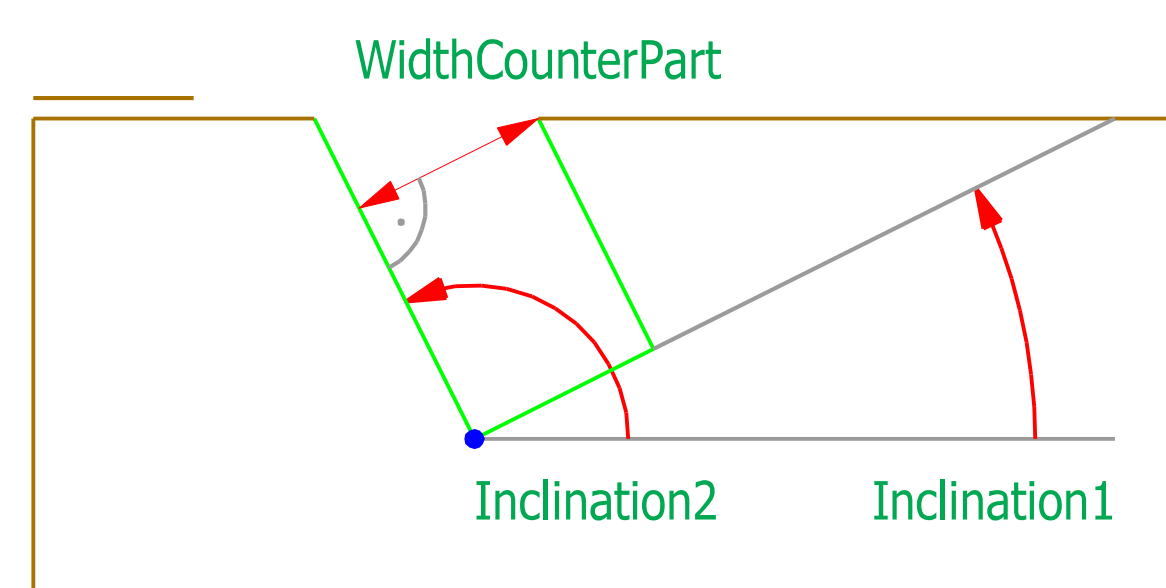
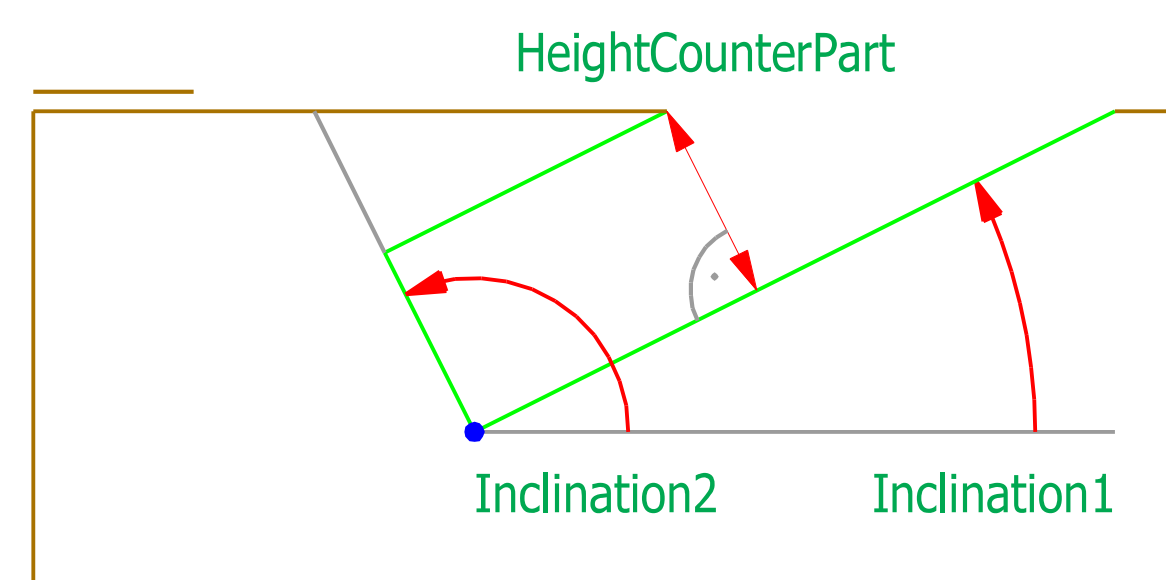
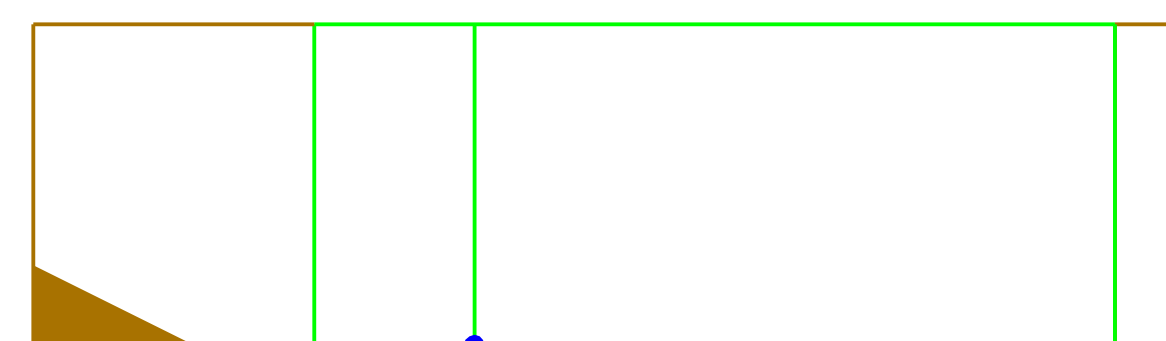

Orientation = end

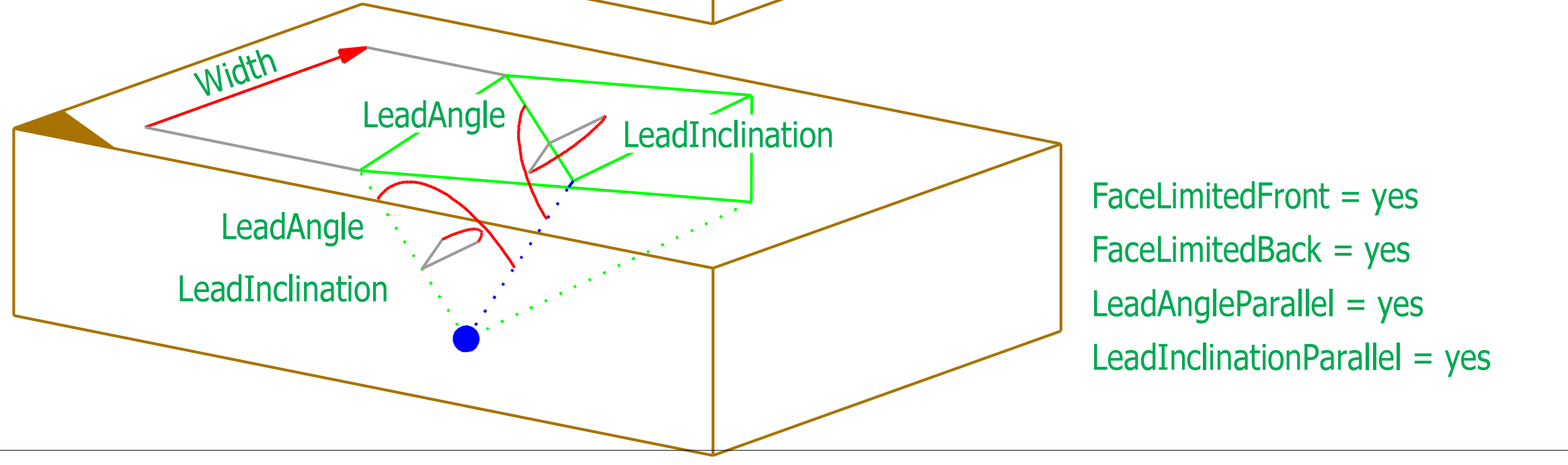
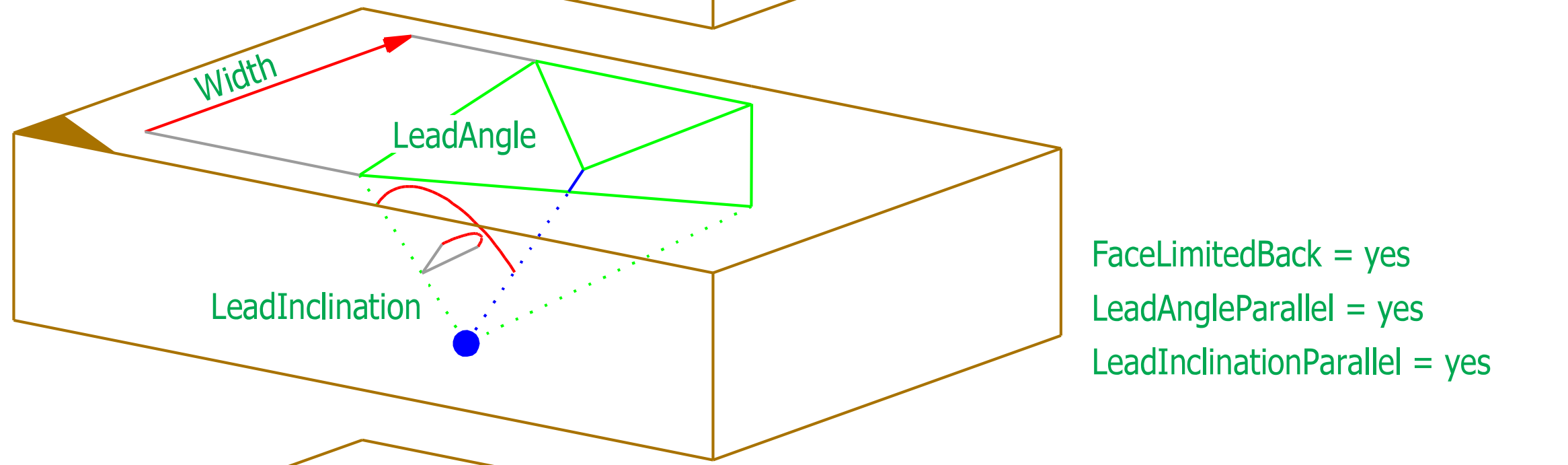
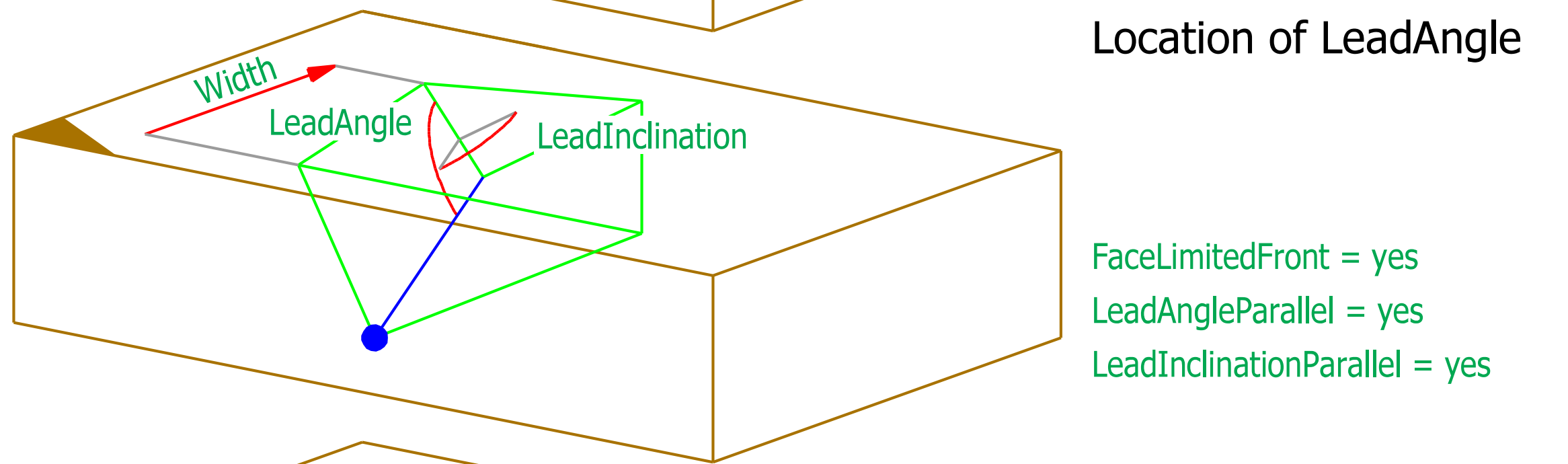
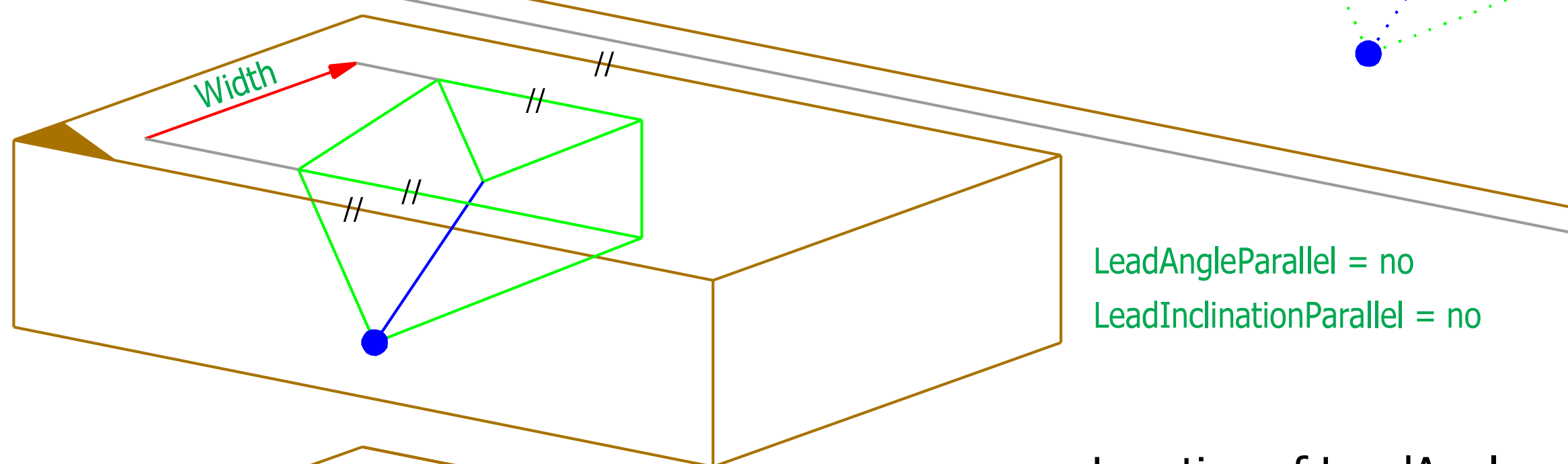
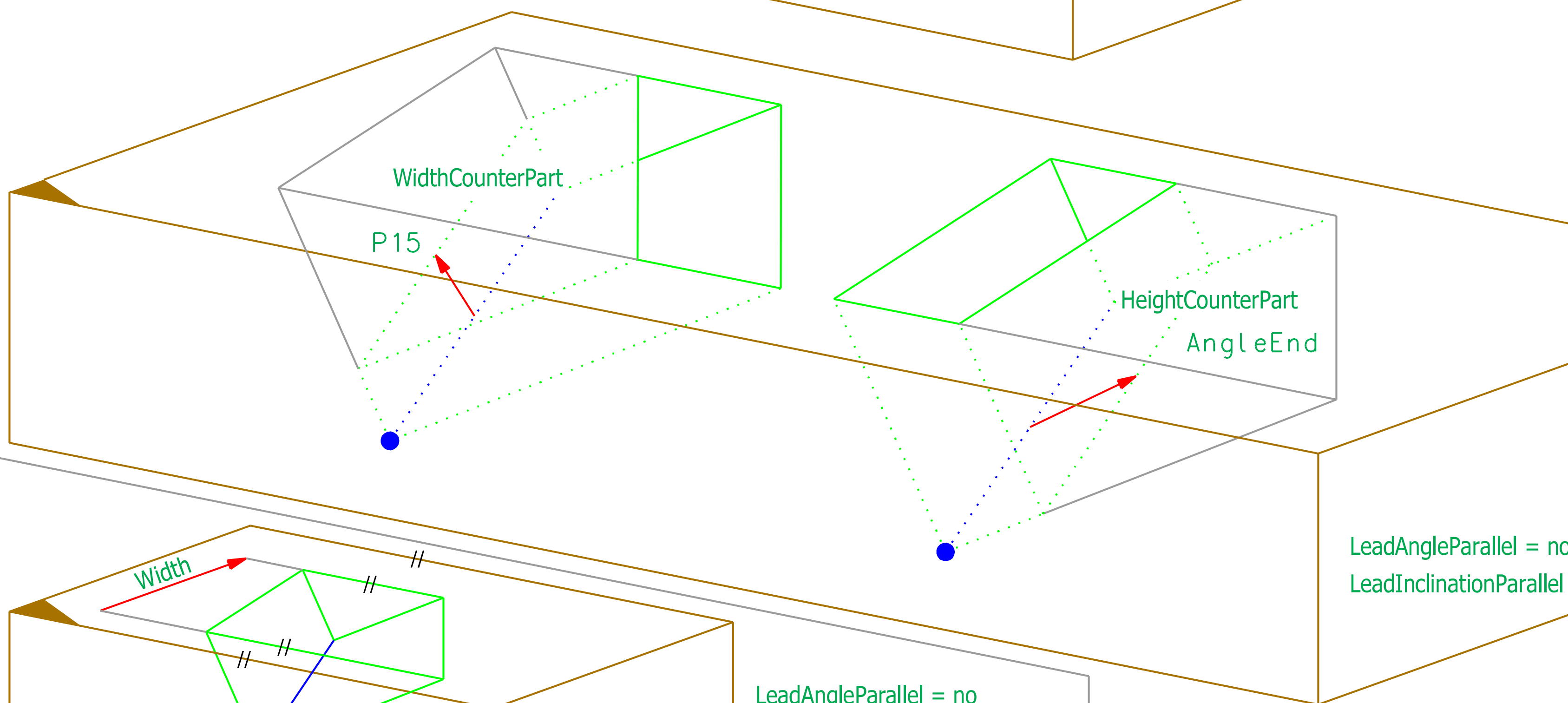
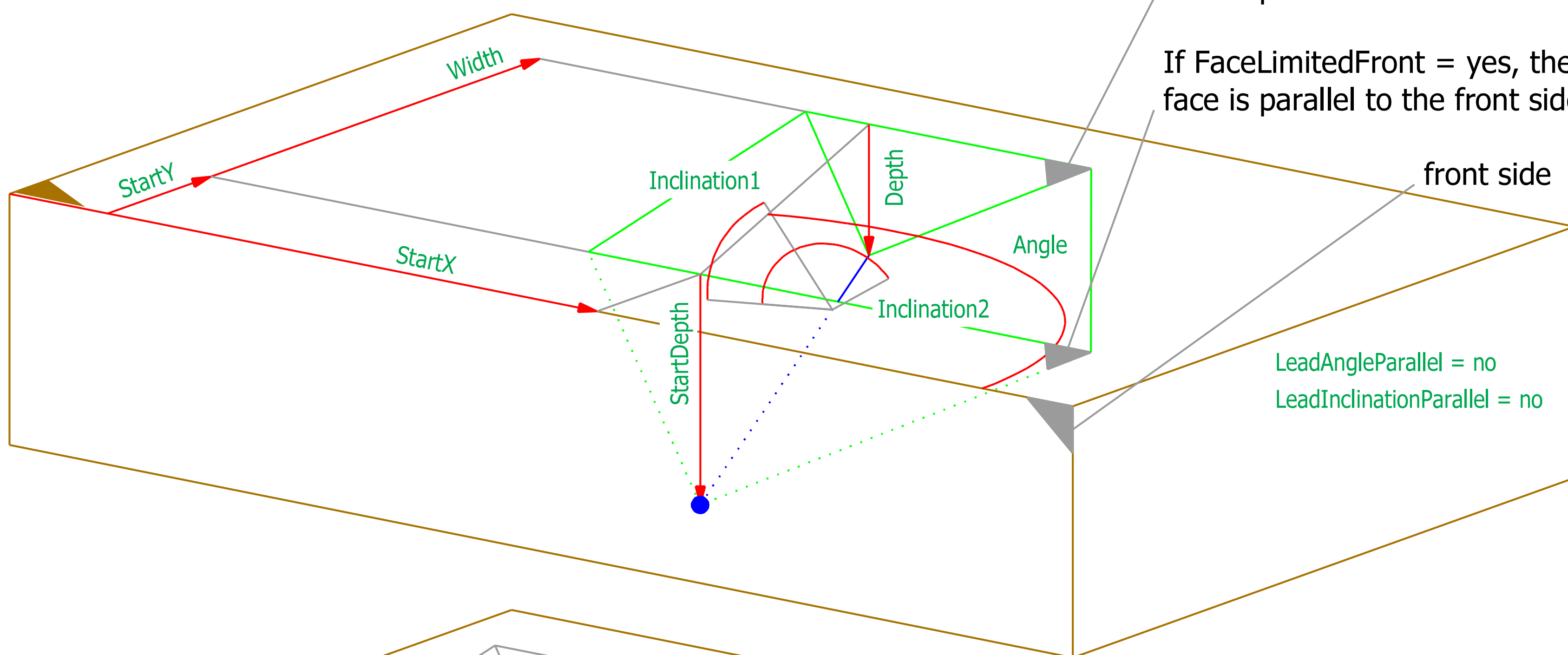

Simple example

Angle = 90
StartDepth = Depth

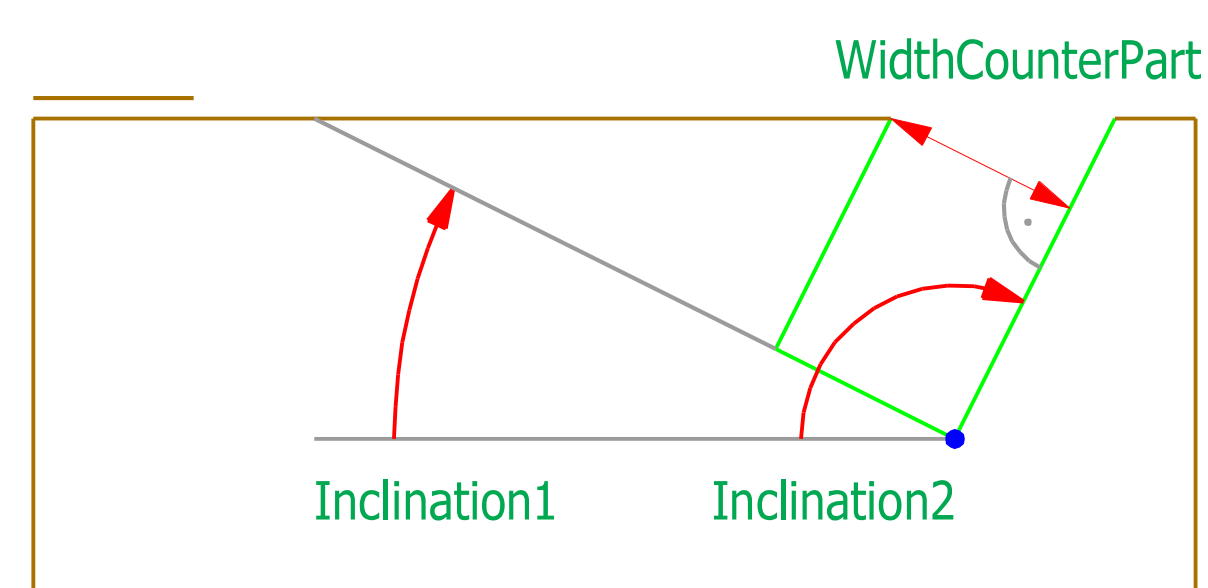
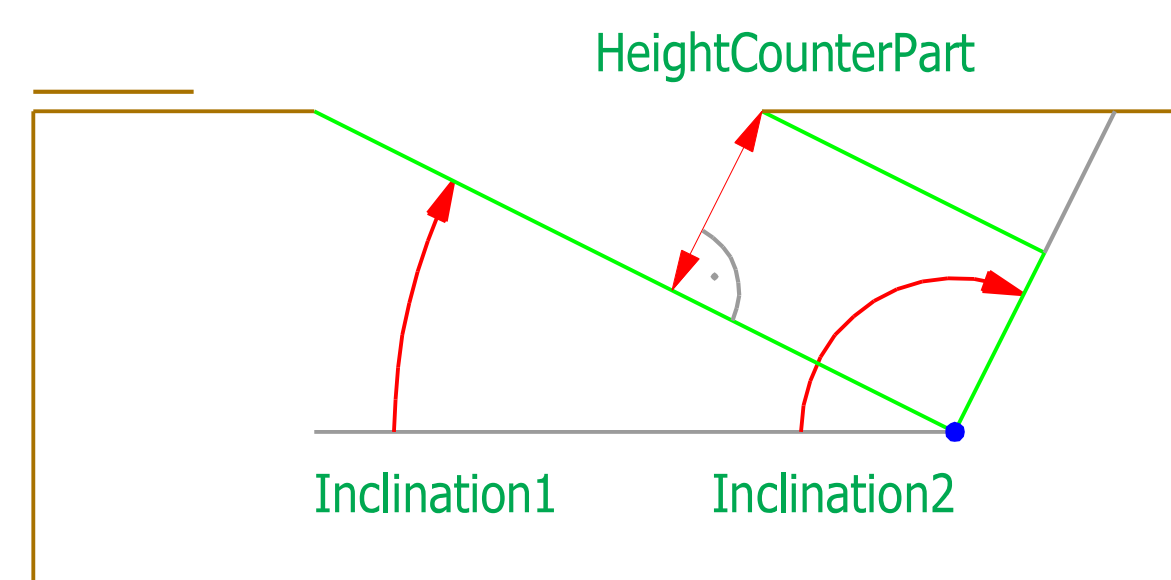
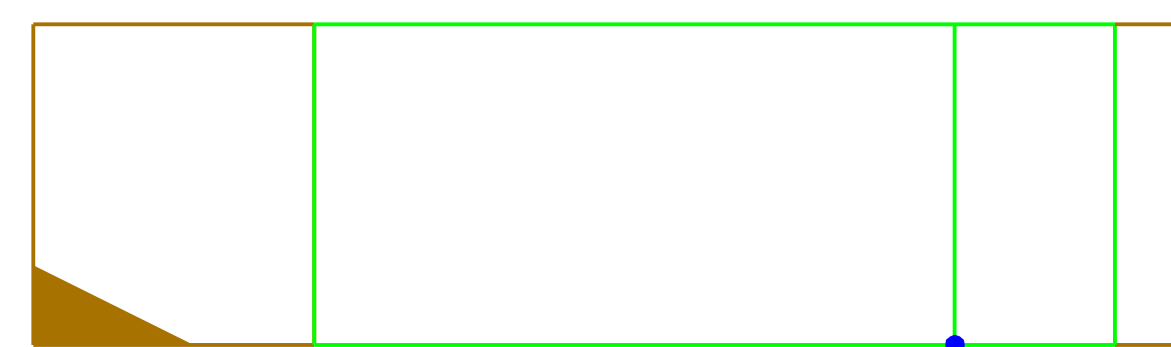

Orientation = start

Another presentation of Inclination1 and Inclination2

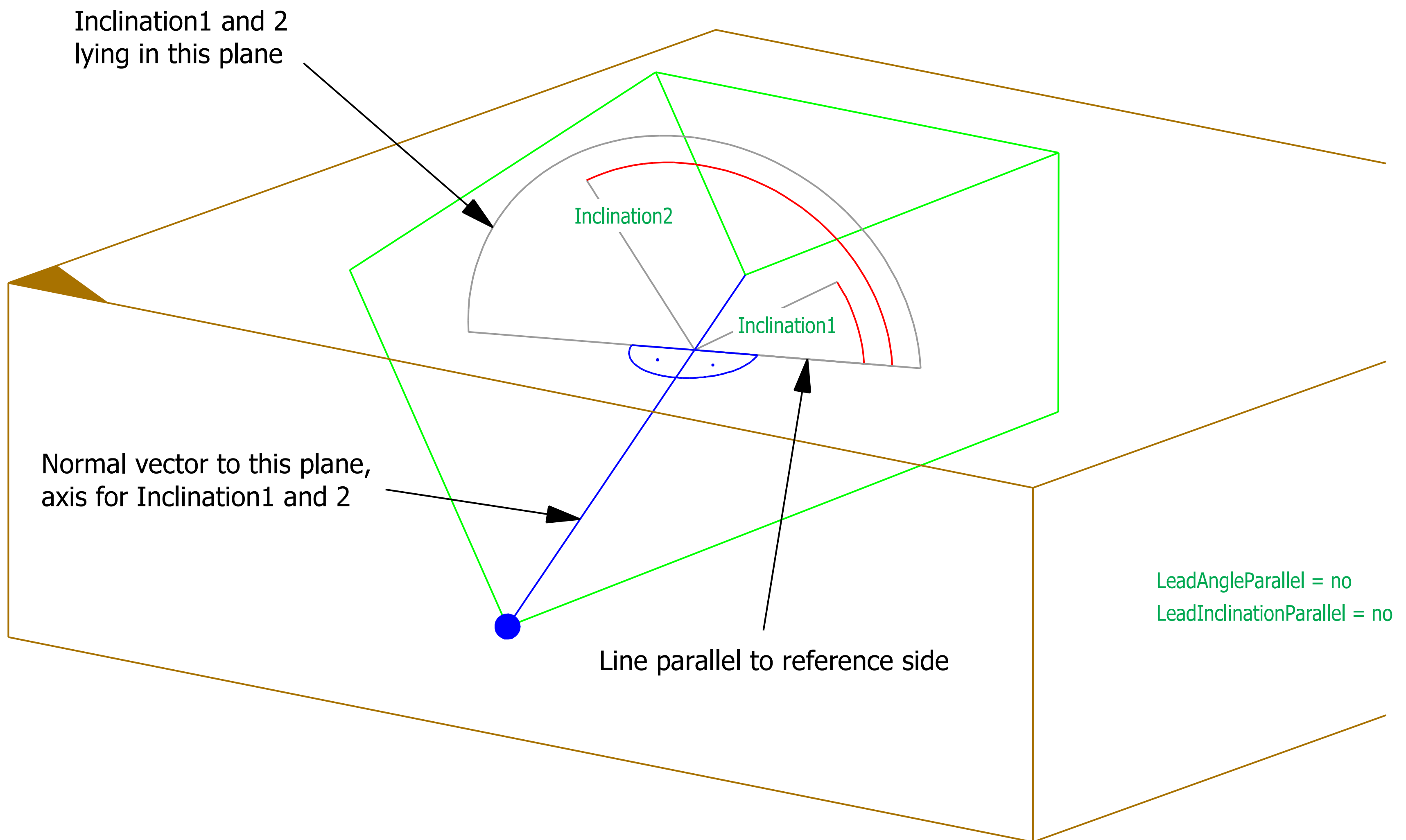

Orientation = end

Another presentation of Inclination1 and Inclination2

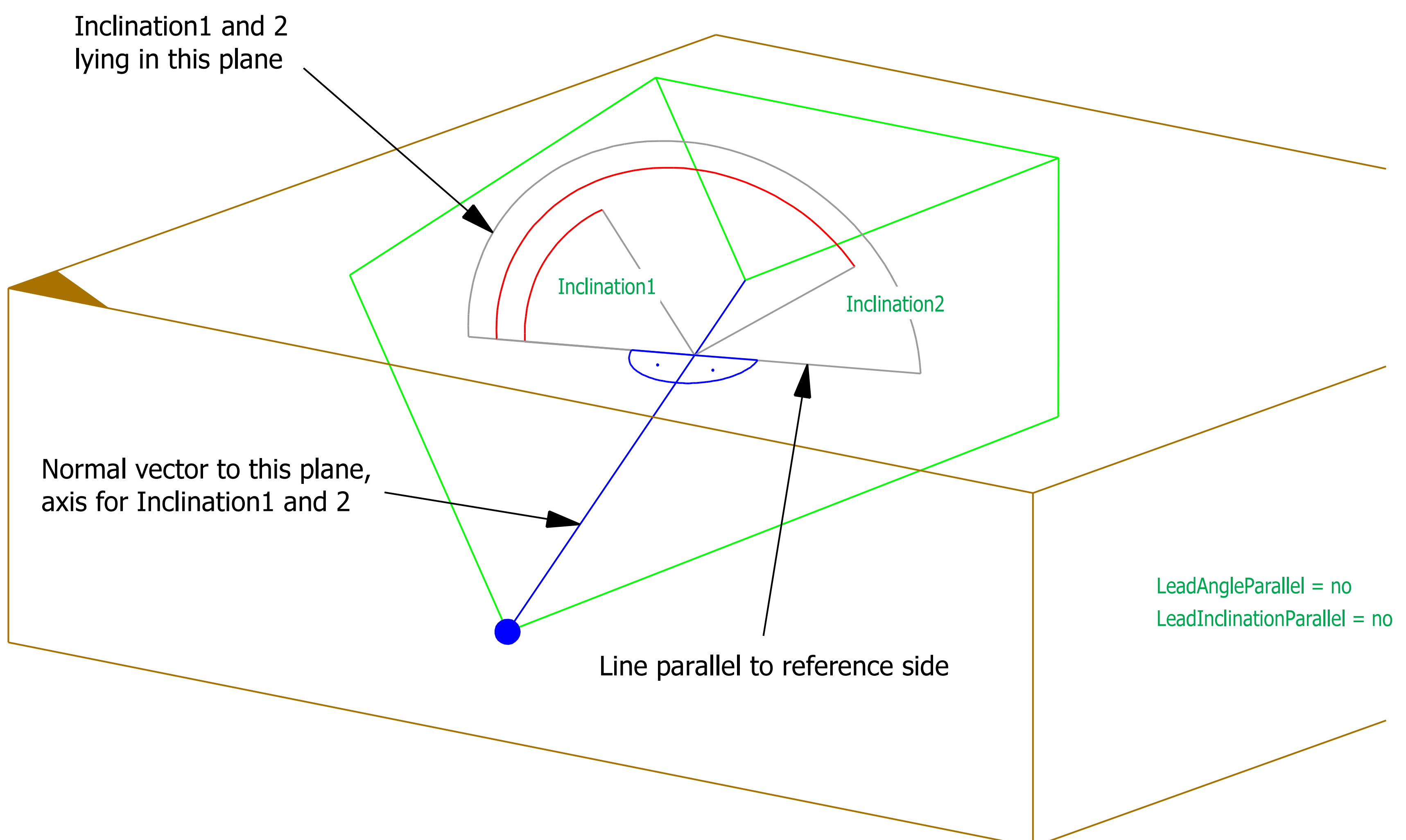

Orientation = start

Another presentation of parameters

View orthogonal to face "Inclination1"

The counterpart enters at the reference edge.

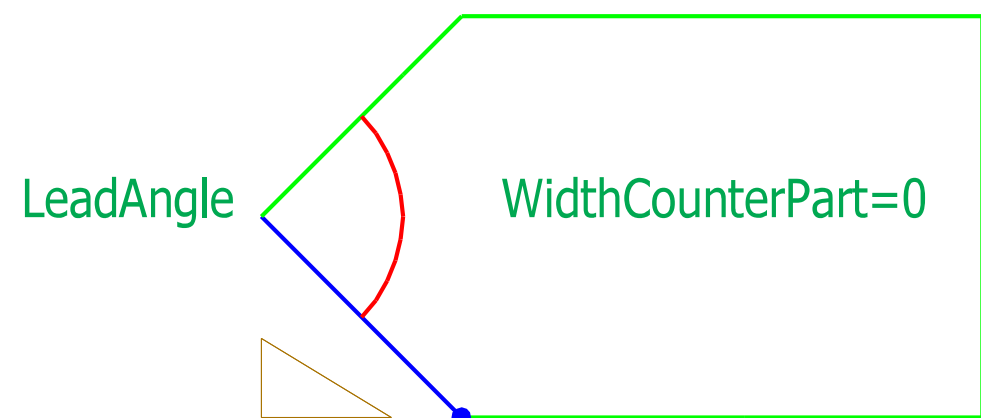

The counterpart enters at opposite of the reference edge.

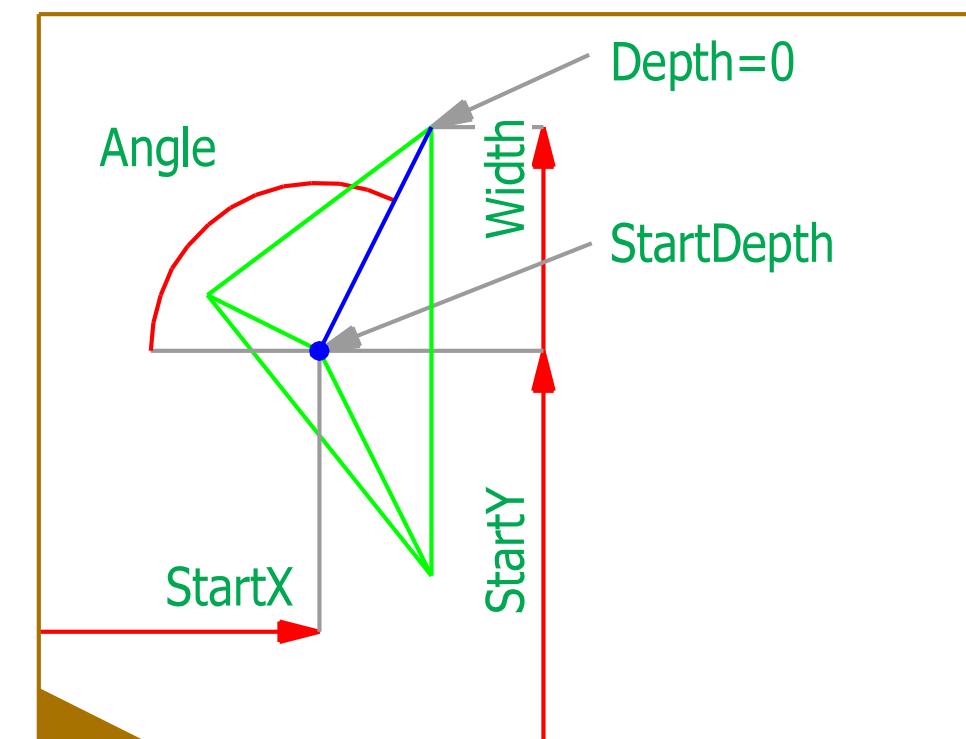
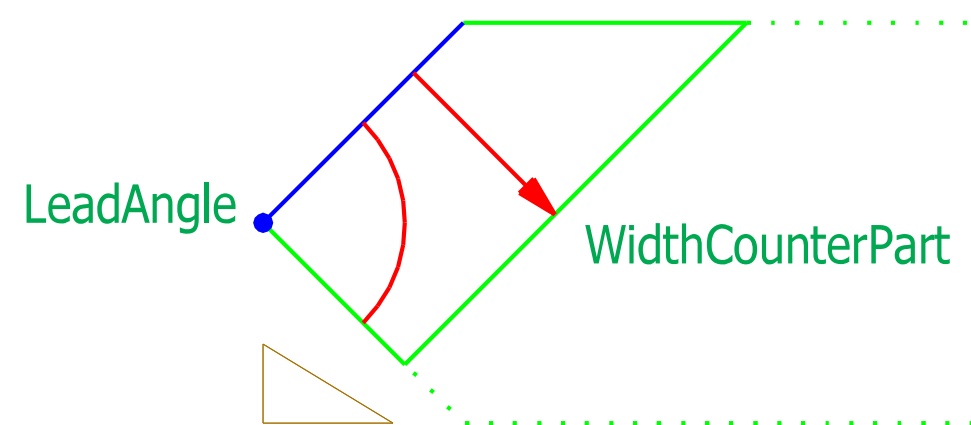
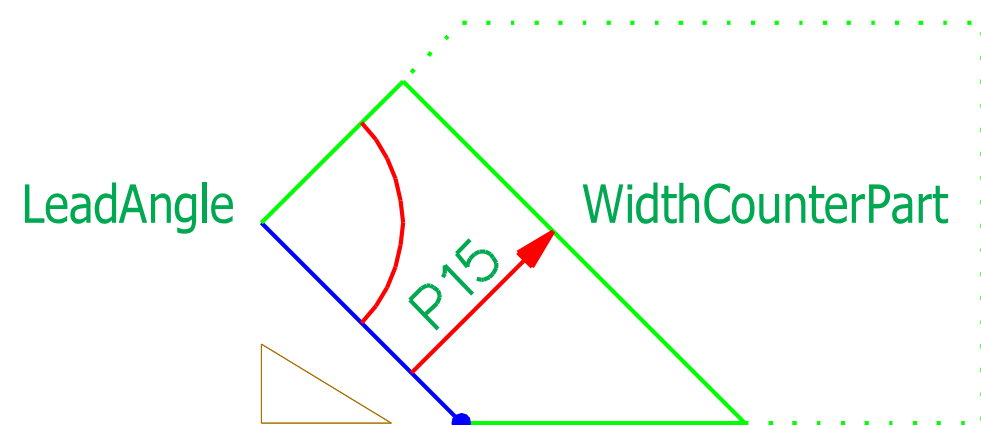
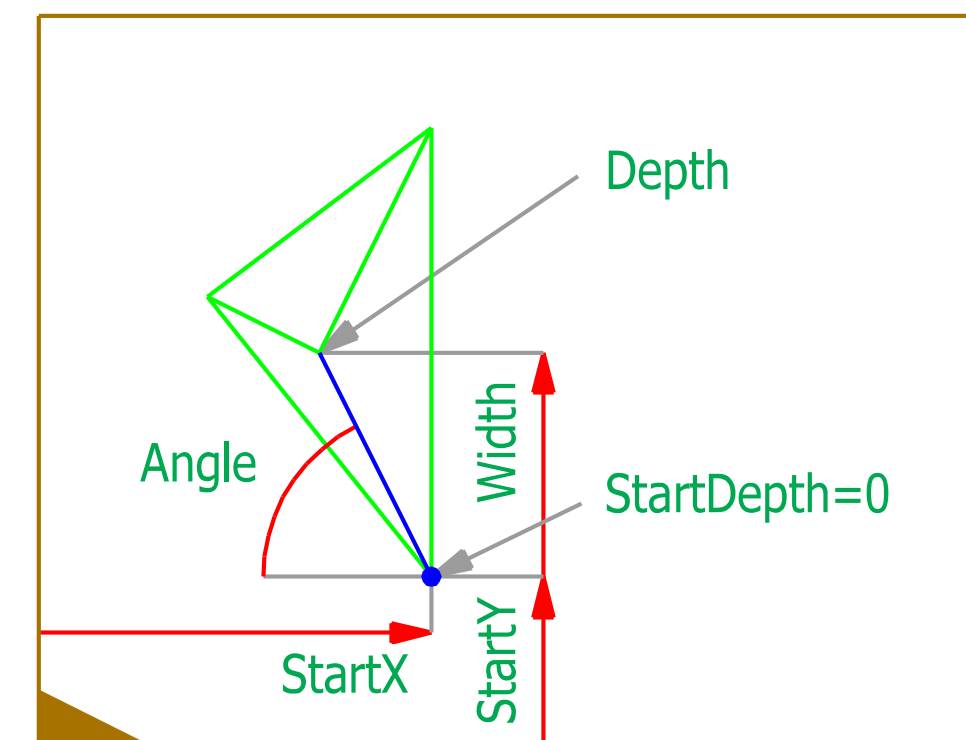
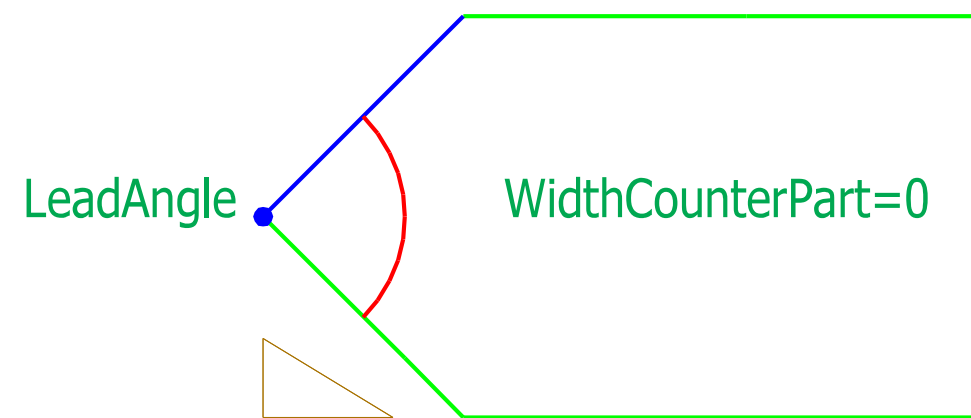

Orientation = end

Another presentation of parameters

View orthogonal to face "Inclination1"

The counterpart enters at the reference edge.

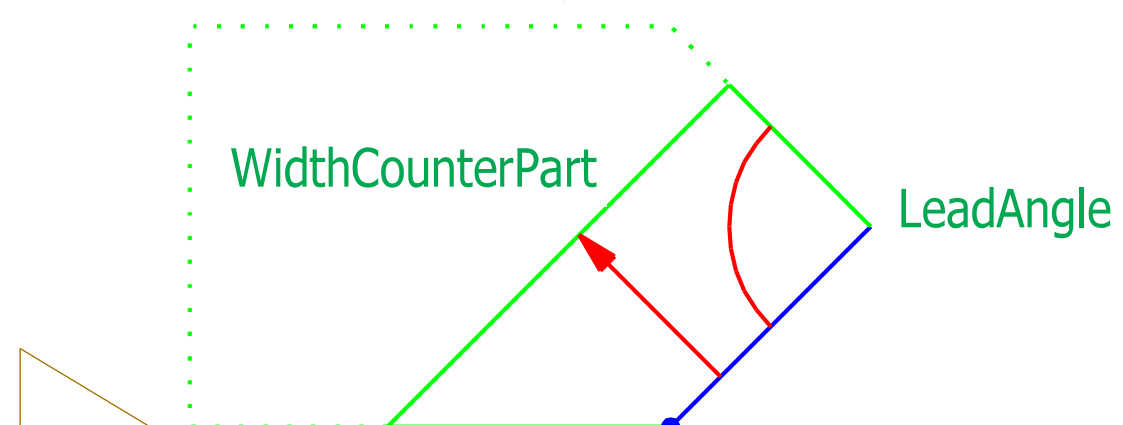

The counterpart enters at opposite of the reference edge.

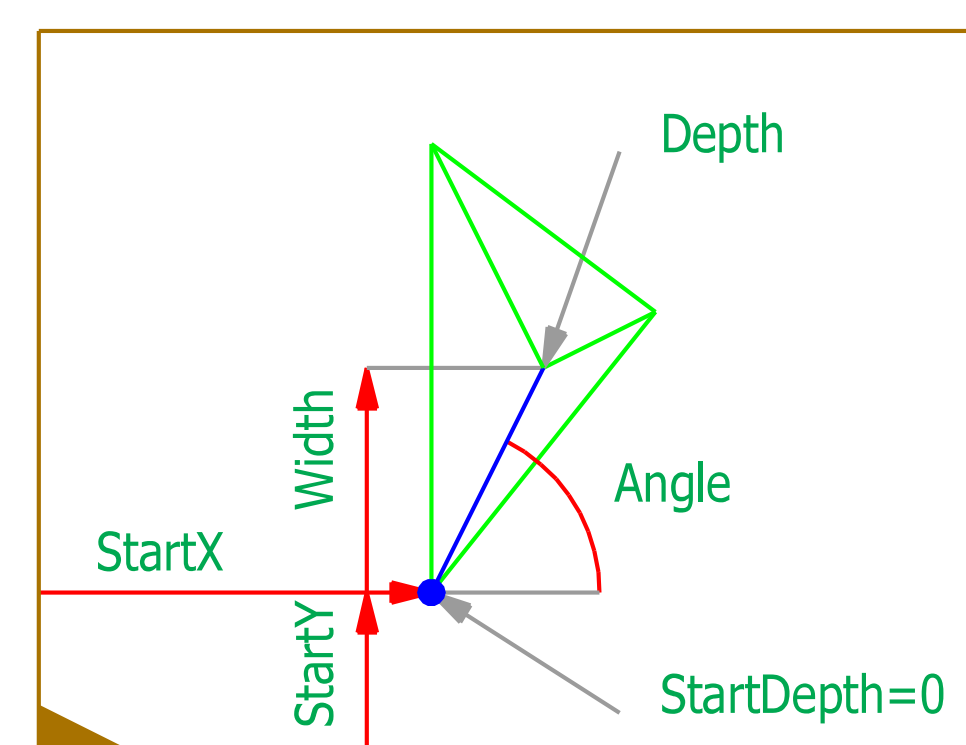
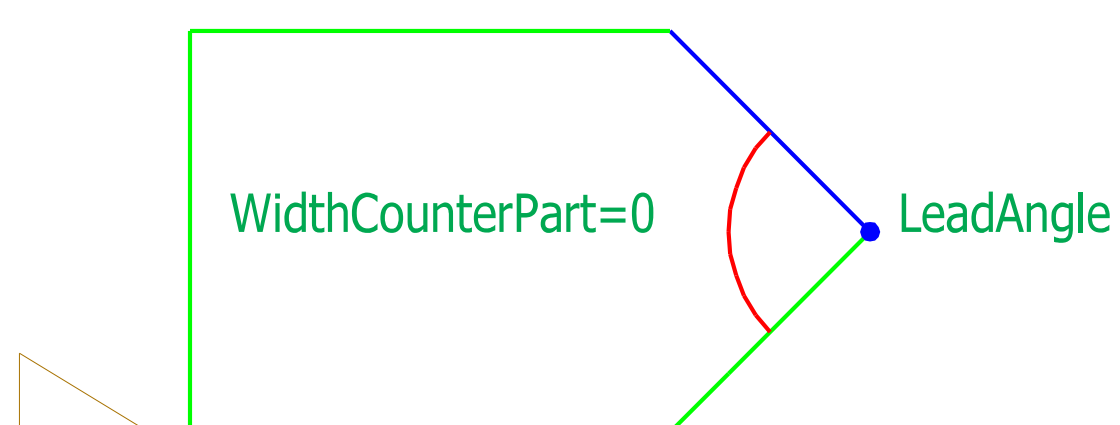
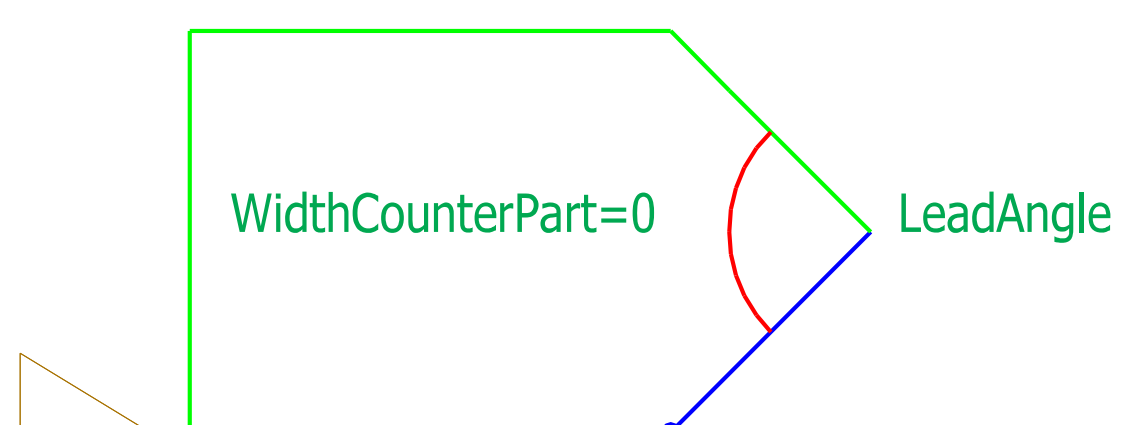
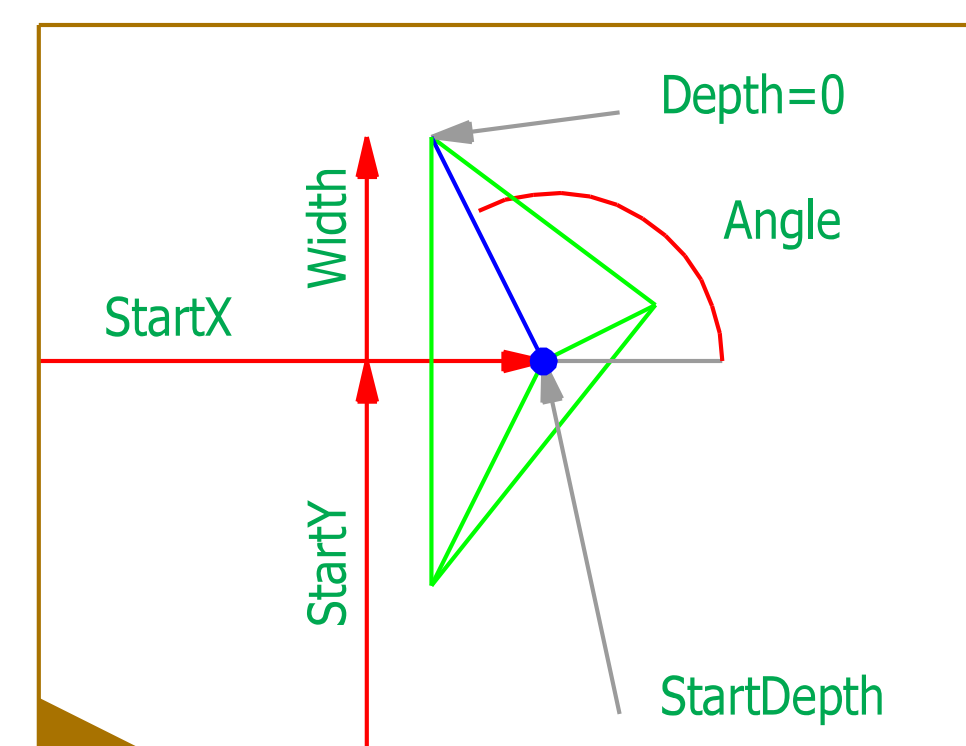
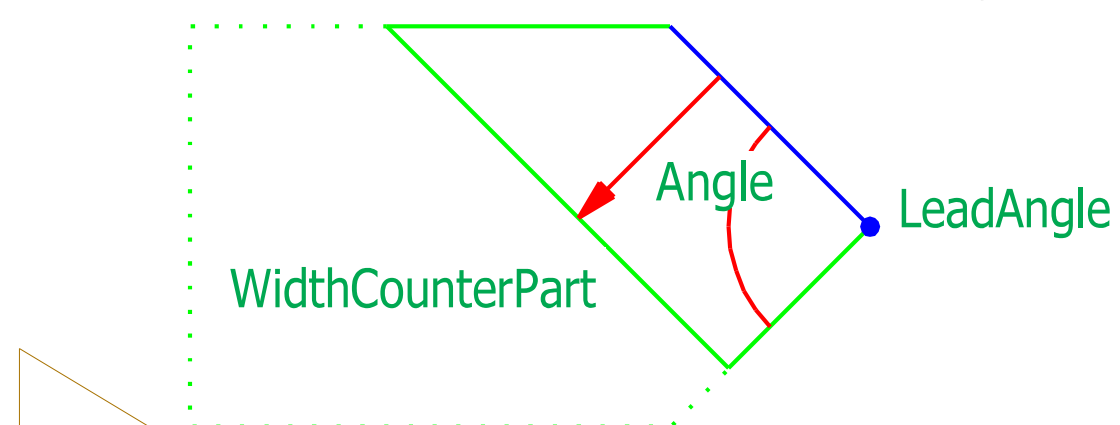

Parameters BirdsMouth

Name	Type	Default	Min	Max
Orientation	OrientationType		start	end
StartX	LengthPosType	0.0	-100000.0	100000.0
StartY	WidthNType	0.0	-50000.0	50000.0
StartDepth	WidthType	20.0	0.0	50000.0
Angle	AngleType	90.0	0.1	179.9
Inclination1	Angle2Type	45.0	0.0	180.0
Inclination2	Angle2Type	135.0	0.0	180.0
Depth	WidthType	20.0	0.0	50000.0
Width	WidthType	0.0	0.0	50000.0
WidthCounterPartLimited	BooleanType	no	no	yes
WidthCounterPart	WidthType	120.0	0.0	50000.0
HeightCounterPartLimited	BooleanType	no	no	yes
HeightCounterPart	WidthType	120.0	0.0	50000.0
FaceLimitedFront	BooleanType	no	no	yes
FaceLimitedBack	BooleanType	no	no	yes
LeadAngleParallel	BooleanType	yes	no	yes
LeadAngle	AngleType	90.0	0.1	179.9
LeadInclinationParallel	BooleanType	yes	no	yes
LeadInclination	AngleType	90.0	0.1	179.9
RafterNailHole	BooleanType	no	no	yes